

CNC milling and tapping center

EZ Series



EZ Series



- EZ series is designed for 3C, hardware, and automotive industries. Variety spindle speed 12,000rpm, 20,000rpm, or 24,000rpm are available for different machining requirements.
- Standard equipped with direct-drive type spindle for better tapping precision and avoids belt life issue of belt type spindle.
- Servo type roller cam ATC gives high production efficiency.
- Adopt A type column structure and it has the advantage of keeping dynamic stability under the rapid traverse of 1.2G.



Main specifications

Item	Unit	EZ-5 (EZ-5A)	EZ-7 (EZ-7A)
X/Y/Z axis travel	mm	510/400/300 (350)※1	710/400/300 (350)※1
Spindle	rpm	12,000 (Opt. 24,000 ※2)	
Max. tapping speed	rpm	6,000	
Rapid traverse	m/min	60/60/60	
Cutting feedrate	m/min	20/20/20	
Table size	mm	600x400	850x400
Max. loading capacity	kg	250	
Servo motor	kW	1.5/2.2/2.2 (Mitsubishi) ※3	
Max. tool weight	kg	3	
Tool amounts	pc	EZ-5/7 : 16 (21) / EZ-5/7A : 20	

※1 : The travel of Z axis in EZ-5A and EZ-7A is 350mm ※2 : Max. speed in FANUC spindle motor is 20,000rpm
 ※3 : FANUC servo motor :1.8/1.8/3 kW

CONTENTS

- 03 Industry application/ Machining capacity
- 04 Main structure
- 05 ATC
- 06 Security/Operation
- 07 Peripheral accessories
- 08 Spindle output and torque chart
- 09 Machine dimensions · Std./Opt. accessories
- 10 Specifications

Industry application / Machining capacity

Industry application



Machining capacity

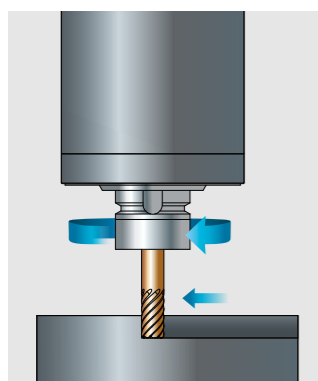

End mill	Ø20 mm
Material	S45C
Cutting depth/width	2/2 0 mm
Spindle speed	3,182 rpm
Feedrate	1,273 mm/min
Chip disposal rate	51 cm ³ /min

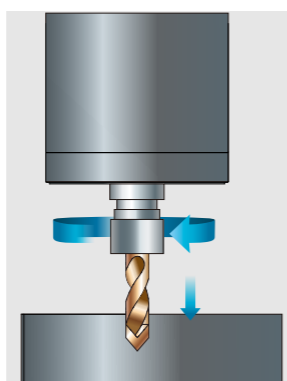

Drill	Ø16 mm
Material	S45C
Spindle speed	490 rpm
Feedrate	88 mm/min
Chip disposal rate	18 cm ³ /min

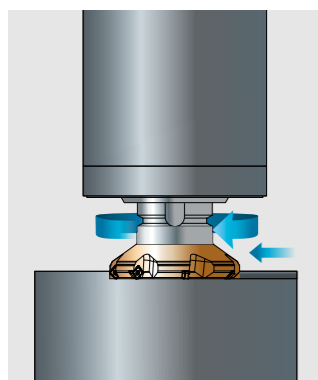

Face mill	Ø80 mm
Material	S45C
Cutting depth/width	1/70 mm
Spindle speed	1,200 rpm
Feedrate	1,200 mm/min
Chip disposal rate	84 cm ³ /min

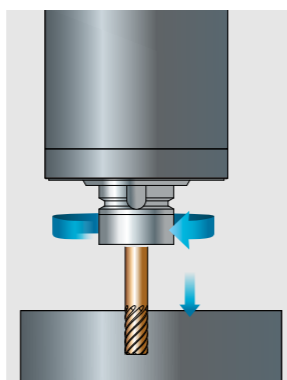

Tap	M16
Material	S45C
Max. M hole	M16x2
Min. M hole	M2x0.5
Spindle speed	6,000 rpm

※Note: The data above comes from the test values of EZ-5 with 12,000 rpm direct drive type spindle.

Main structure

EZ series adopts Finite Element Analysis (FEA) to ensure the machining efficiency and maintain the machining precision.

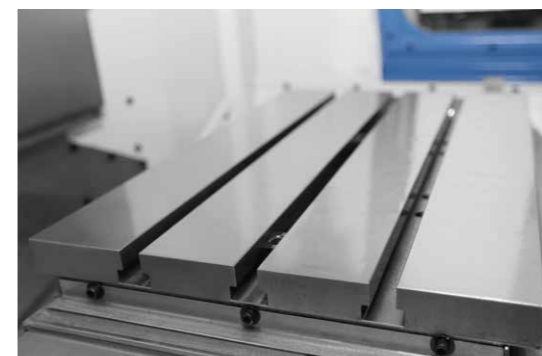

Fine ground table surface with excellent flatness.

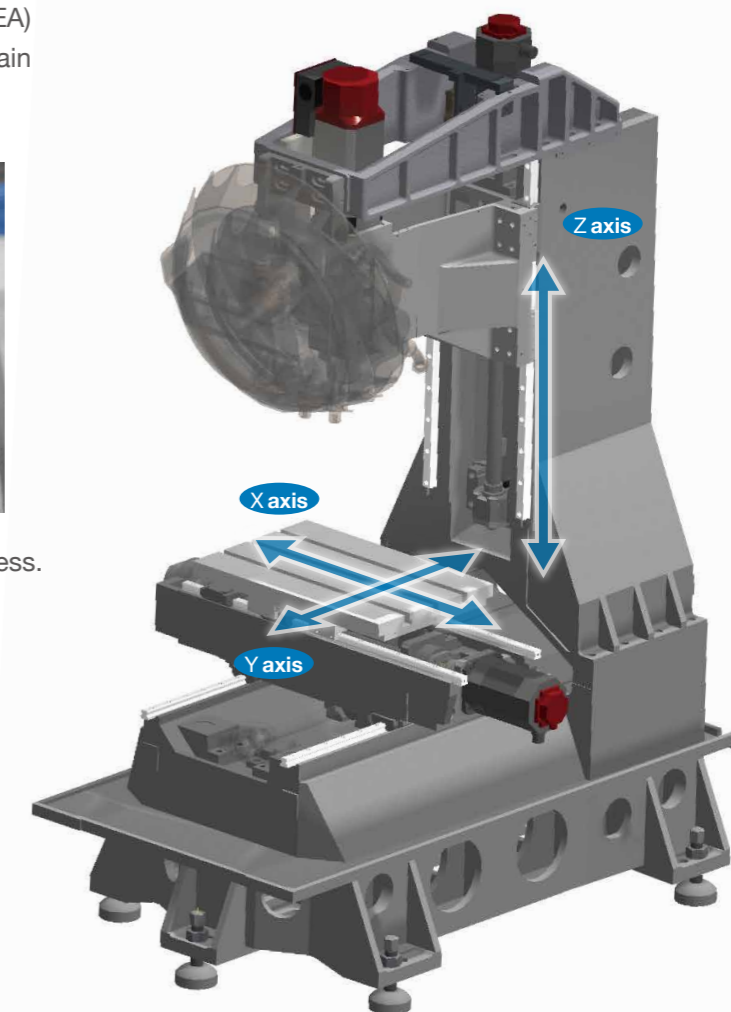

Working area

EZ-5

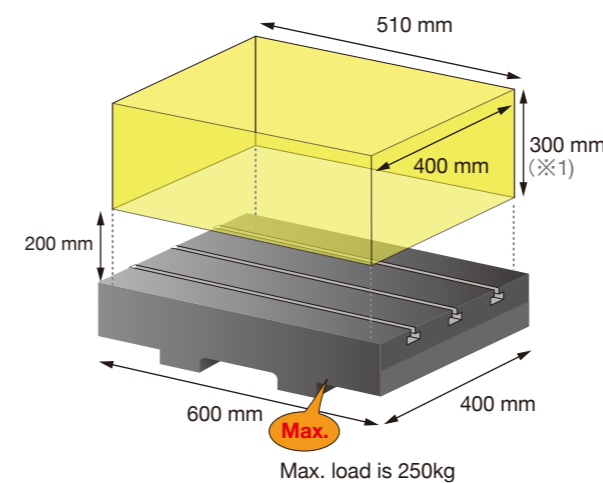

EZ-7

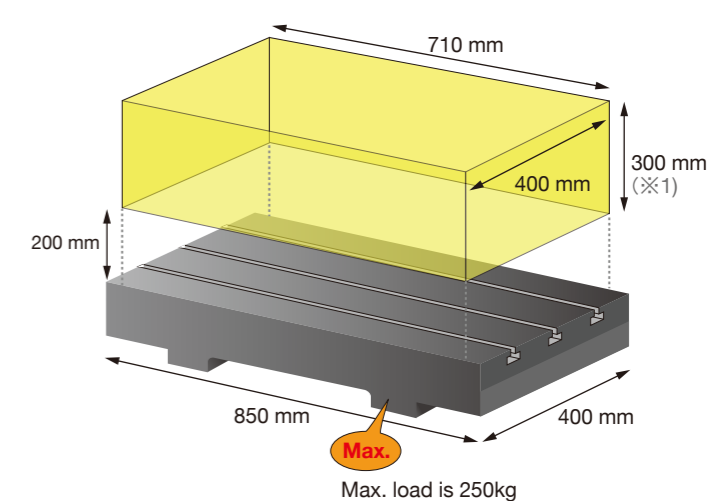

※1 : The travel of Z axis of EZ-5A and EZ-7A is 350mm

Automatic tool changer (ATC)

EZ-5

High speed servo motor drives tool magazine fast only in 0.2 seconds for each indexing time. With cam type tool changer, tool changing is fast and noise is low.

Tool to Tool time	1.2 sec
Time of opposite tool changing	0.9 sec
Tool capacity	16 (Opt. 21)
Max. tool weight	3 kg



Tool to Tool = 1.2 sec

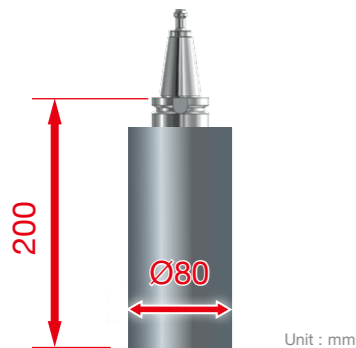

EZ-5A

Arm type changer is adopted for processing tool change. Roller cam type ATC design allows the synchronous actions of tool losing and arm working in a rapidly and stably situation. It shortens the non-cutting time and increases productivity dramatically.

Tool to Tool time	0.8 sec
Tool capacity	20
Max. tool weight	3 kg



Tool to Tool = 0.8 sec

With adjacent tool

Without adjacent tool

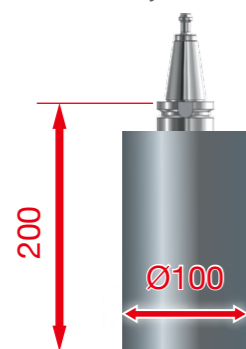
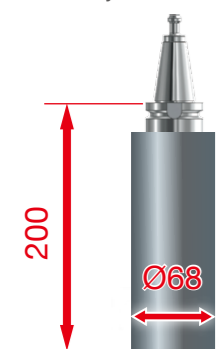

Unit : mm

Safety and operation

Safety

Safety glass window is passed EN12417 standard and certificated by CE. Impact resistance is 200 times more than tempered glass. It improves the safety for operators.



Operation – Easy daily maintenance

Pneumatic unit, lubricant pump and some maintenance items are located on machine side together for easy maintenance.



Chips disposal

- Slanted sheet metal design with coolant flushing design enables to carry chips out of machine easily.
- Special sheet metal prevents machine bed being affected by chips heat. It avoids thermal distortion and maintain machining precision.

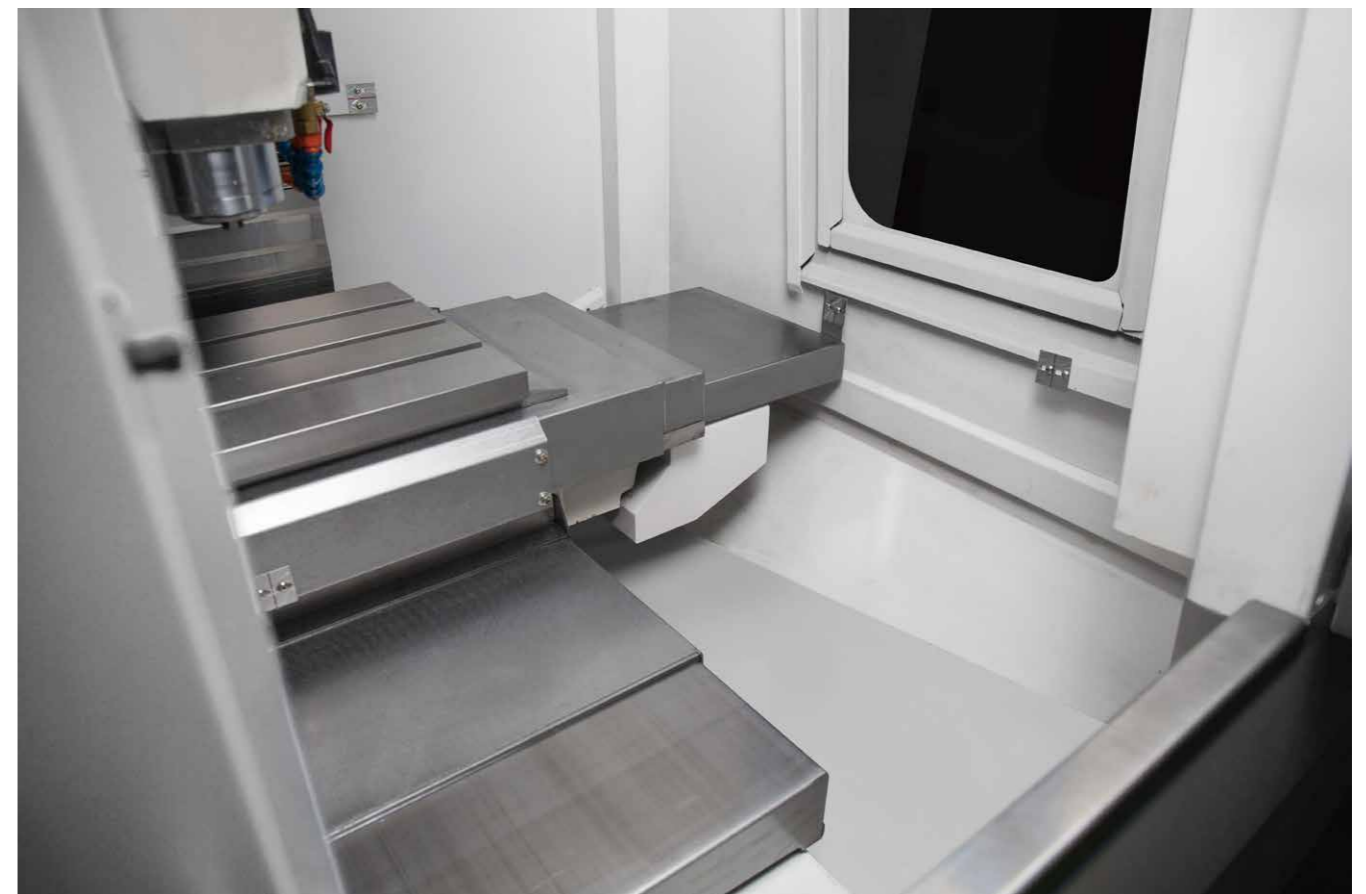

Peripheral accessories

Interior flushing system (Std.)

Adopt 1.3 kW machine bed flushing system for avoiding chip accumulation.

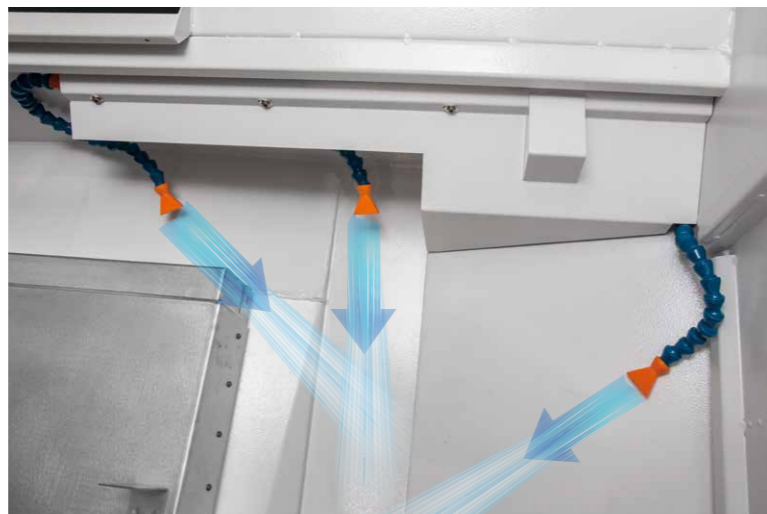

Environment friendly design – Oil-water separator

1. Linear guideways & ballscrews have best efficient lubricant feeding design. Less feeding frequency saves lubricant consumption.
2. Special design guides X/Y/Z axes used lubricant to the center of machine bed.
3. Oil-water separator is equipped for preventing lubricant flow into coolant tank to extend coolant life.

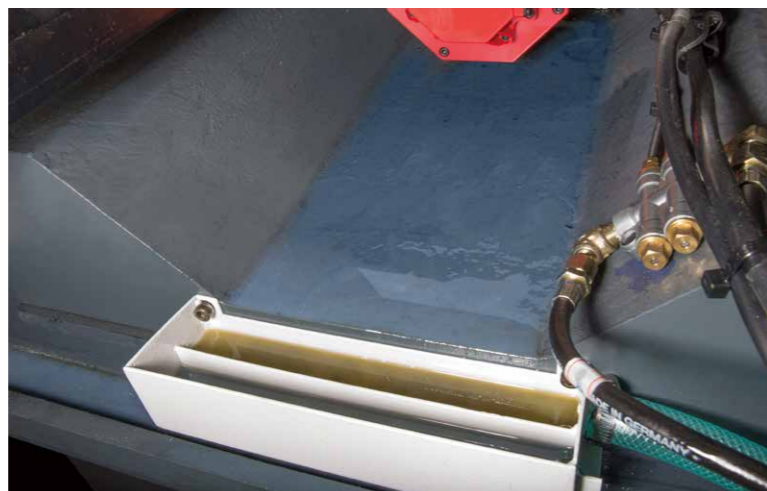

Coolant through spindle

Coolant through spindle (C.T.S.) design provides excellent chip removal in deep hole machining and increase machining efficiency and extend tool life.



Spindle output and torque chart

Spindle motor

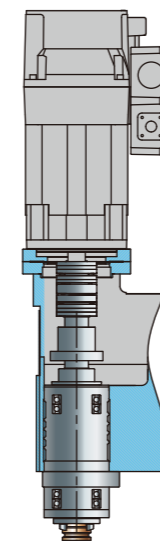

12,000 rpm (Std.) (C.T.S. is available)

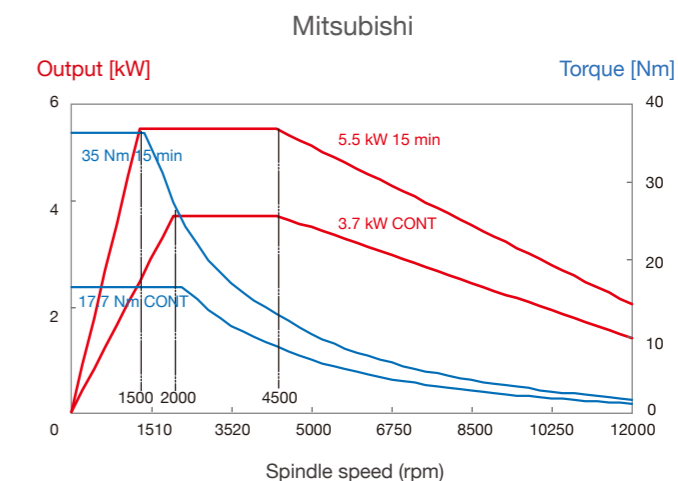

12,000 rpm (Opt.)

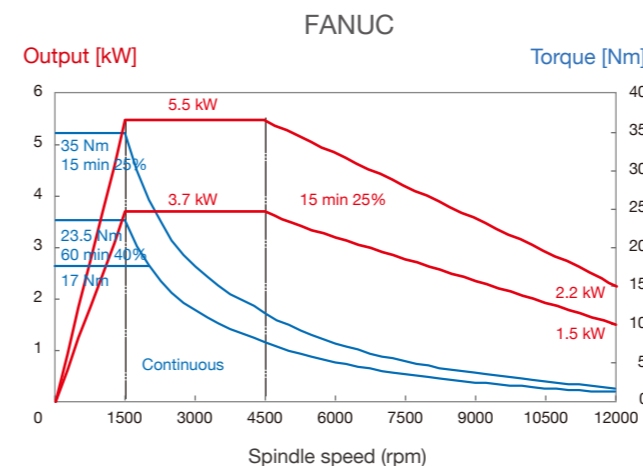

12,000 rpm With C.T.S (Opt.)

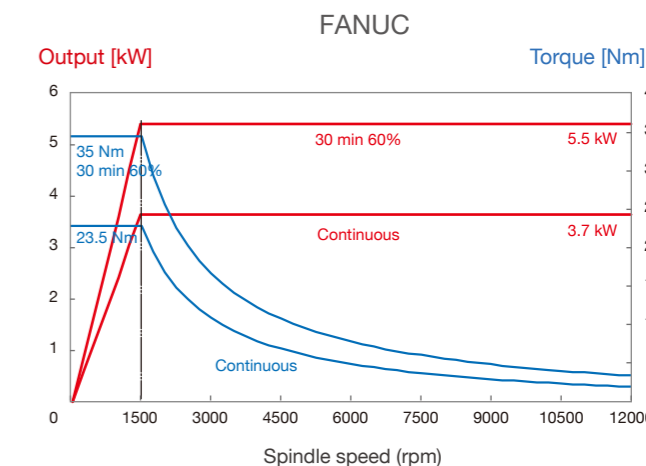

24,000 rpm (Opt.)

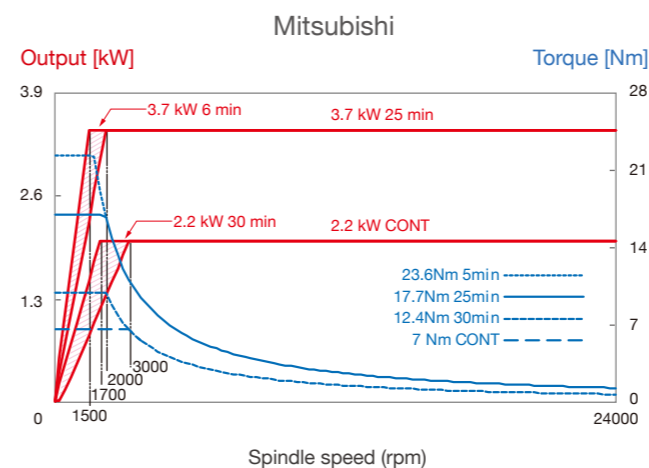

20,000 rpm (Opt.) (C.T.S. is available)

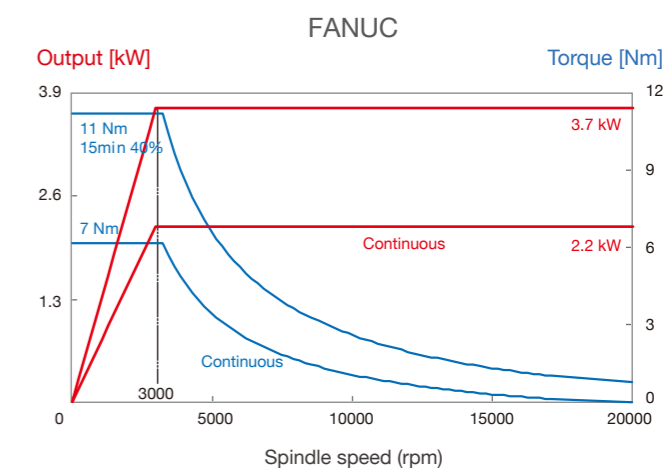

Machine dimensions • Std./Opt. accessories

Specification

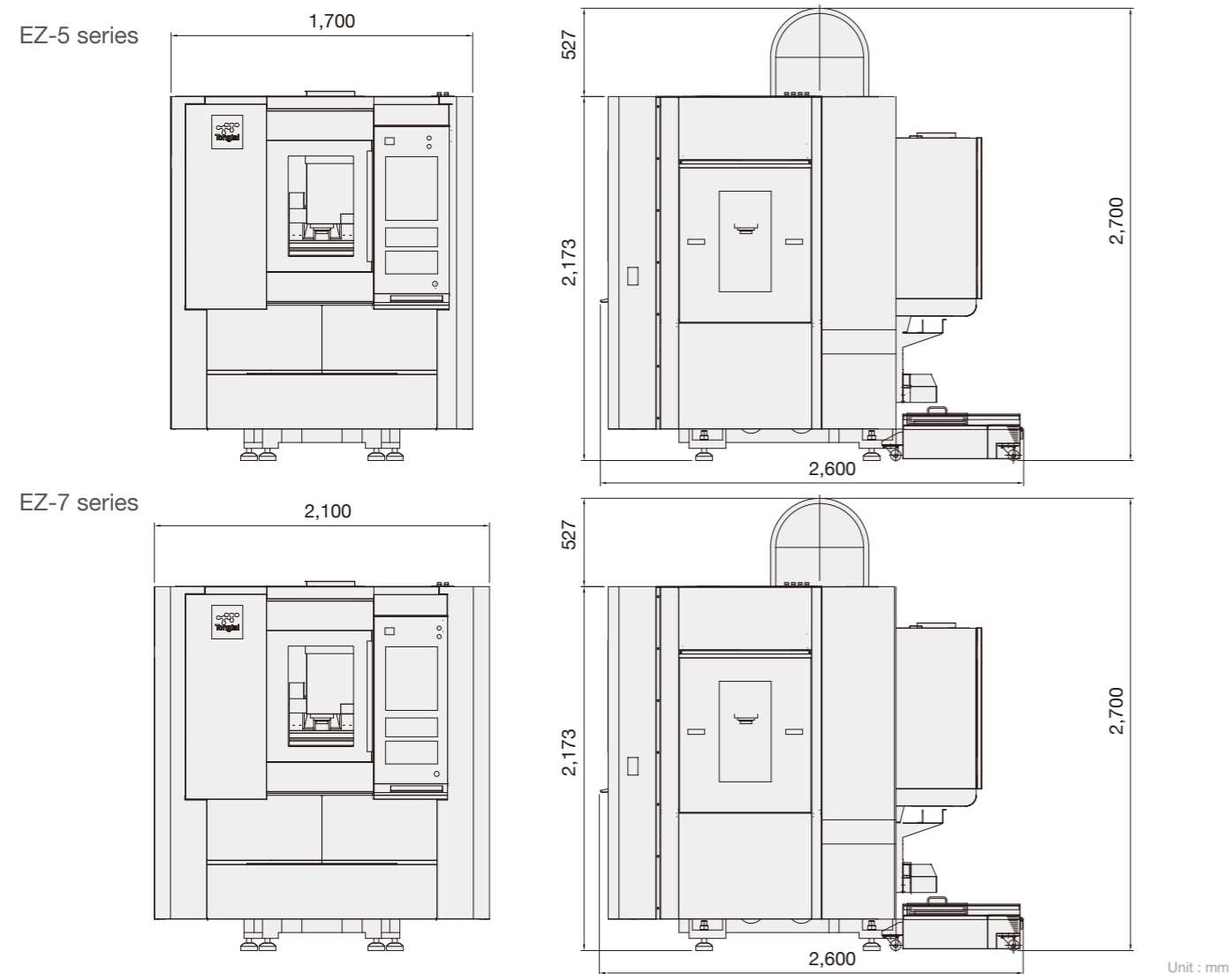

Item	Specification	Unit	EZ-5	EZ-5A	EZ-7	EZ-7A
Table	Table size (L×W)	mm	600×400		850×400	
	Max. loading capacity	kg	250			
	Table height from floor	mm	850			
	T-slot (size×No.)	mm	18×3			
Spindle	Spindle taper		7/24 Taper No. 30			
	Spindle speed	rpm	12,000 (Opt. 20,000/24,000)			
Travel	X/Y/Z axis travel	mm	510/400/300	510/400/350	710/400/300	710/400/350
	Spindle nose to table	mm	200			
Feed	X/Y/Z axis rapid traverse	m/min	60/60/60			
	Cutting feedrate	mm/min	1-20,000			
ATC	Tool shank		BT-30			
	ATC driving method		Servo motor	Motor	Servo motor	Motor
	Tool magazine type		Rotary disc type	Tool arm type	Rotary disc type	Tool arm type
	Tool pick-up		Fixed	Random	Fixed	Random
	Tool capacity	pc	16 (Opt. 21)	20	16 (Opt. 21)	20
	Max. tool diameter	mm	Ø80	Ø68	Ø80	Ø68
	Max. tool diameter (w/o adjacent tool)	mm	Ø80	Ø100	Ø80	Ø100
	Max. tool length	mm	200			
	Max. tool weight	kg	3(*1)			
	Motor	Spindle motor	kW	3.7/5.5		
X/Y/Z servo motor		kW	1.5/2.2/2.2 (Opt. FANUC 1.8/1.8/3)			
Coolant motor		kW	0.18			
Machine size	Width×Depth×Height	mm	1,700×2,600×2,700		2,100×2,600×2,700	
	Weight	kg	2,850		3,150	
Controller			Mitsubishi M70V type A (FANUC 0i-F)			

Standard/optional accessories

	Standard	Optional
LED lighting	●	
Manual pulse generator	●	
Workpiece counter	●	
Tri-color warning light	●	
Tool magazine	●	
Flushing system	●	
Spindle blow	●	
Interlock	●	
Coolant around spindle	●	
Coolant through spindle		○
Disc type oil skimmer		○
Air gun set		○
Coolant gun set		○

	Standard	Optional
Automatic door		○
Oil-mist collector		○
Coolant tank with chip conveyor		○
Spindle cooling device		○
Transformer / Stabilizer		○
Tool breakage detector		○
Standard 4 th axis (available to D210)		○
Hydraulic units and interface		○
A/C for electrical cabinet		○
CE standards		○
Automatic power off system		○
Automatic tool taper washing		○

*1.The max. tool weight is provided for reference. Different shapes and centers of gravity will influence the results.

◎The spindle with 12,000/16,000 rpm is available with C.T.S. (24,000 rpm w/o C.T.S.)

◎Specifications may be changed without prior notifications.